

Installation Instruction

Product Code: 806743 806750
 Product Description: Emergency Kit

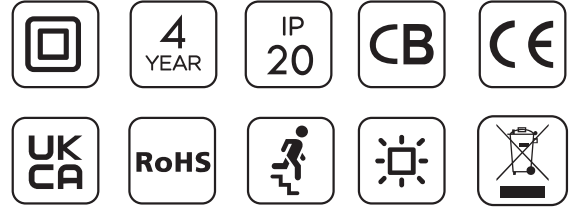

Specification

Emergency Power: 2W
 EM Duration: 3 hours
 Ambient Temp: 0-55°C
 Function: Autotest
 Battery: LiFePO4 6.4V 1.5Ah
 Warranty: 4 years (battery 2 years)

Routine Testing

Testing should be carried out in accordance with the recommendations of BS5266 & EN50172.

1. Do not switch off unswitched mains supply after installation. If interruption is unavoidable, the batteries must be disconnected or damage to the batteries may occur. Leave the luminaire on continuous charge for 24 hours.
2. A monthly functional test should be conducted manually.
3. Annually, a full three hour duration test should be conducted manually.
4. Batteries should be replaced when the luminaire no longer meets the 3 hours duration performance.
5. Testing is performed by interrupting the unswitched supply for the test duration manually or self-test function complying with IEC62034. During testing the luminaire should remain illuminated in emergency mode.
6. Ensure that the 'charge indicator' is 'ON' during 'Charging Mode'. If the charge indicator (LED) is unlit, this signifies a fault.
7. Replace faulty light source and batteries immediately. To assist with this testing, a test record is included below. To increase the chance of a fault being reported between monthly tests, it is desirable that staff are made aware of the purpose of the indicator.

Testing Record

Product: _____

Location: _____

Installation Date: _____

Month	Functional/Duration	Year 1	Year 2	Year 3	Year 4	Year 5
1						
2						
3						
4						
5						
6						
7						
8						
9						
10						
11						
12						

Installation Instruction

Dimension

Emergency Conversion

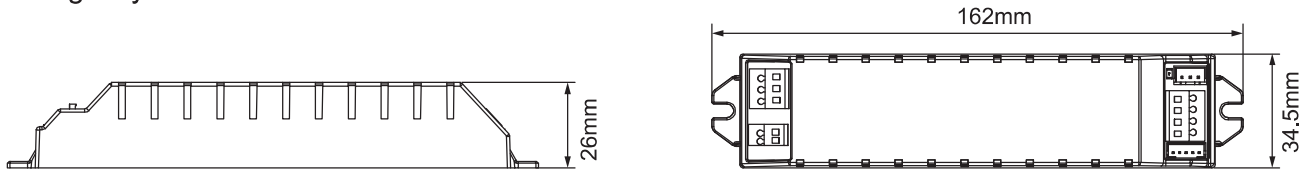

Battery

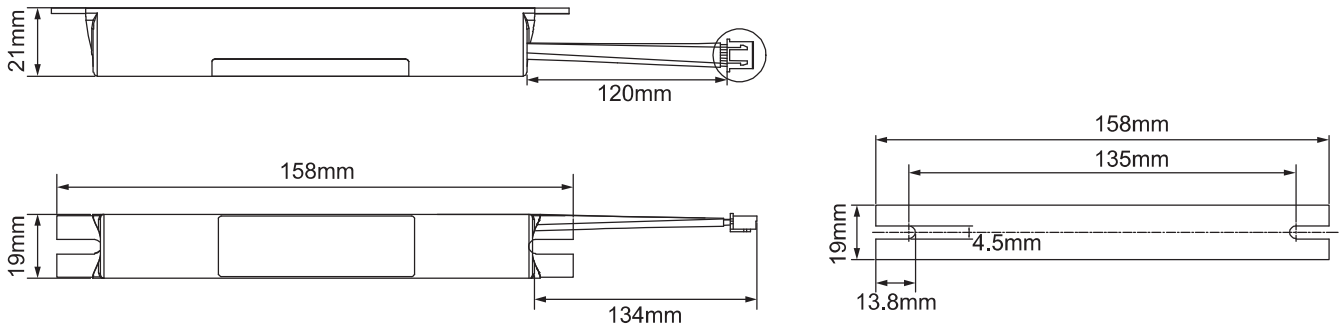

Indicator & Test button

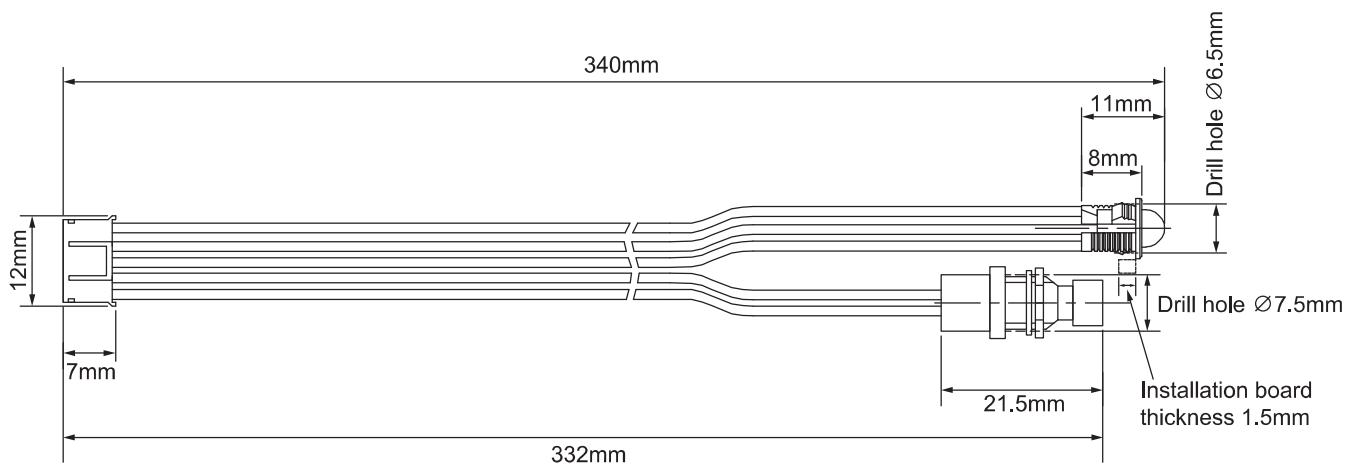

Installation Instruction

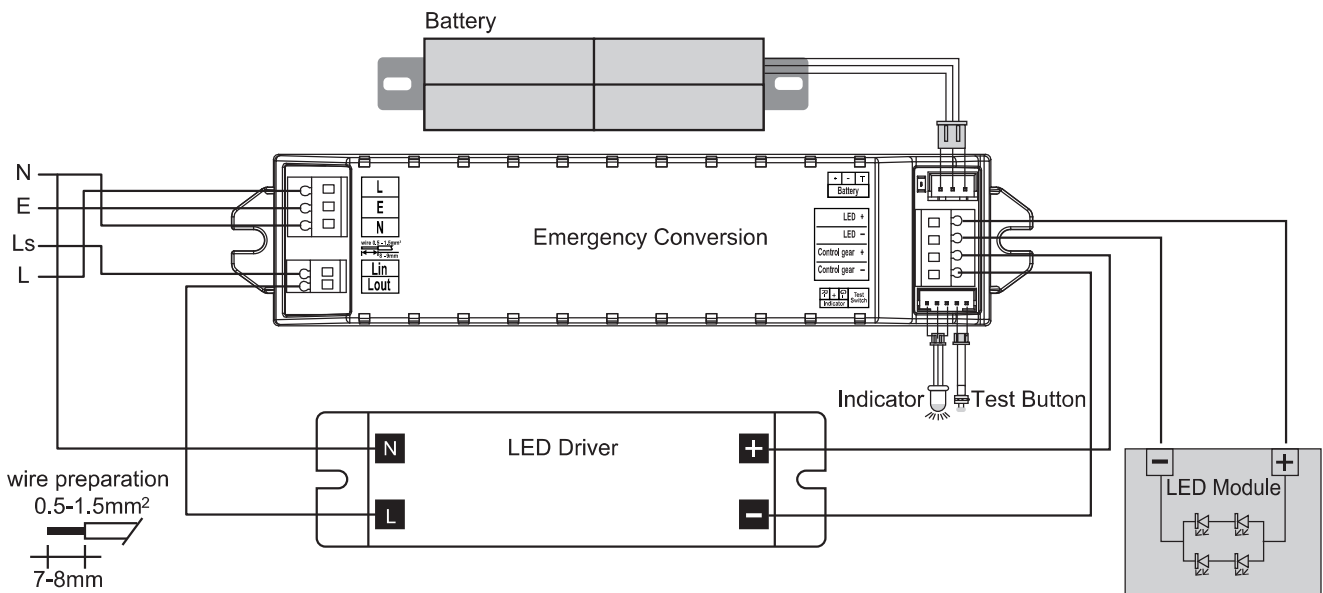

Storage

1. The battery should be preserved at the clean and dry environment, do not exceed storage time as following definition.
2. Storage time: battery is charged in ex-work condition (as per required law of dangerous good needs or UN38.3), for ensuring battery performance, do not exceed storage time as following definition.
3. -20°C to 50°C, <1month, The battery should be recharged every 1 month.
4. -20°C to 40°C, 1-3months, The battery should be recharged every 1 month.
5. -20°C to 35°C, >3months, The battery should be recharged every 3 months
6. If the battery is preserved for a long time (more than 9months), the battery should be discharged and recharged once. Even so, it will impact the battery performance.
7. If LFP battery is stored for more than 3 months at temperature above 35°C, may need supplemental charge before its use with luminaire. (Refer battery datasheet for final recommendation).

Driver Compatibility Cautions

1. The LED driver should support output hot wiring, as during the self-test, the LED driver will enter into open circuit and re-connection state with a short time.
2. For 806743 Emergency Kit 60V, the LED driver Uout max can't exceed 120V. And for 806750 Emergency Kit 200V, the LED driver Uout max can't exceed 400V.
3. LED driver should operate normally at 0.6 times rated supply voltage or lower, based on the changeover operation requirement according to Clause 21 of IEC 61347-2-7.

Specifications For Autotest

Function Test









The function test is conducted every month for 3 minutes to check whether the battery connection is abnormal and discharge the battery and the connection of LED module.

Duration Test

An initial duration test is conducted when the battery is connected to the controller for the first time and connected to mains, but after 24 hours charging.

The yearly duration test is conducted for 3 hours on one day within the 300th day to the 365th day every year. It will also check the connection of battery and LED module.

Description corresponding to the color and status of the charge indicator

Charge Indicator Color	Status	On Time (Seconds)	Off Time (Seconds)	Description
Green	 Permanent on	/	/	Normal status when mains connected
	 Slow flash	1s	1s	Duration test running
	 Fast flash	0.2s	0.2s	Function test running
	 Normal flash three times only	0.5s	0.5s	Time reset
Red	 Permanent on	/	/	Battery connection is abnormal or failure
	 Slow flash	1s	1s	Lamp connection is abnormal or failure
	 Fast flash	0.2s	0.2s	Duration failure - the capacity of the battery is decay
Both Off	 Off	/	/	Emergency mode

It should be taken to check connectivity or replace the abnormal battery or lamp

Test button for manual inspection on function test or duration test

Mode of operation

Mode	Description
Press for <2s	Simulate emergency mode.
Press for 3-5s	Start duration test manually. The test can be aborted by pressing off (1-2s). * Must be conducted when the initial duration test finished and after another 24 hours battery charging.
Press for 5-8s	Start Function test manually for 60s. The test can be aborted by pressing off (1-2s).
Press for >10s	Time Reset.

Note:

When the mains is on, the green indicator will be permanent on. It will check the connection of battery and LED module. If it is a non-maintained fitting, the connection of LED module no need to be checked. When the mains is off, no test will perform.

The luminaires which perform the function and duration tests must be connected to the mains supply for at least uninterrupted 24 hours. If the mains is off during these tests, the tests will be postponed for 3 days.

When the fault is corrected, the indicator will only be reset to its normal status after mains reconnected or test switch pressed.

An accuracy of the timing of the test interval is ensured that it has an accuracy of ± 75 s per week. The timing function will be retained through periods of mains supply failure or interruption for up to 7 days.